



US 20050189874A1

(19) **United States**

(12) **Patent Application Publication**

Park et al.

(10) **Pub. No.: US 2005/0189874 A1**

(43) **Pub. Date:**

Sep. 1, 2005

(54) **ORGANIC ELECTROLUMINESCENCE
DISPLAY DEVICE AND METHOD OF
FABRICATING THE SAME**

Publication Classification

(51) **Int. Cl.⁷** **H01J 1/62; H01J 63/04**

(52) **U.S. Cl.** **313/504**

(76) **Inventors:** **Moon-Hee Park**, Busan-si (KR);
Chang-Su Seo, Suwon-si (KR);
Sang-Hun Oh, Yongin-si (KR)

(57) **ABSTRACT**

Correspondence Address:
MCGUIREWOODS, LLP
1750 TYSONS BLVD
SUITE 1800
MCLEAN, VA 22102 (US)

An organic electroluminescence display device including a thin film transistor, a first electrode layer, a second electrode layer, and an organic layer. The thin film transistor includes a semiconductor layer, a gate electrode disposed over the semiconductor layer, and source and drain electrodes insulated from the gate electrode. The first electrode layer is coupled to either the source electrode or the drain electrode, and the first electrode layer and the gate electrode are disposed on the same layer. The second electrode layer is disposed above the first electrode layer, and an organic layer, which includes at least a light emitting layer, is interposed between the first electrode layer and the second electrode layer.

(21) **Appl. No.:** **11/062,938**

(22) **Filed:** **Feb. 23, 2005**

(30) **Foreign Application Priority Data**

Feb. 26, 2004 (KR) 2004-13005

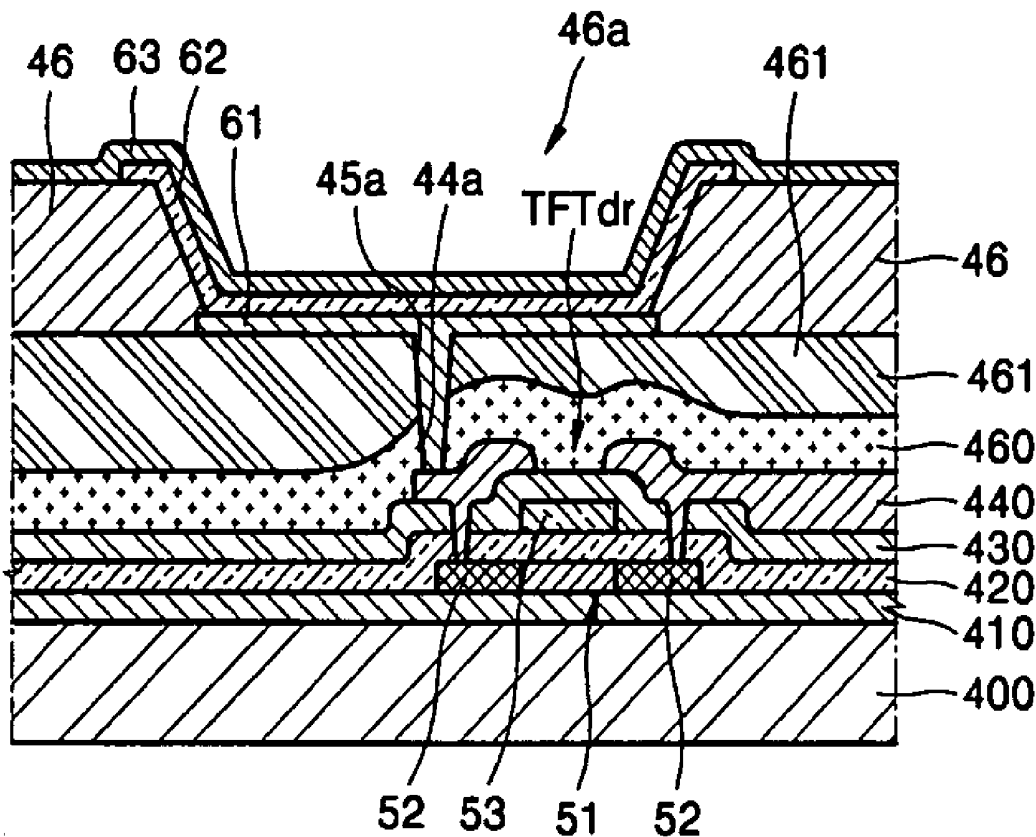

FIG. 1

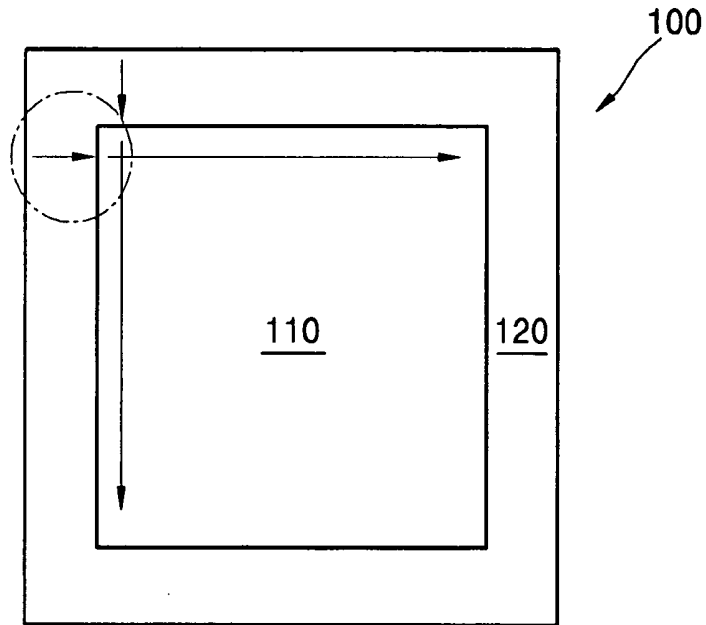

FIG. 2

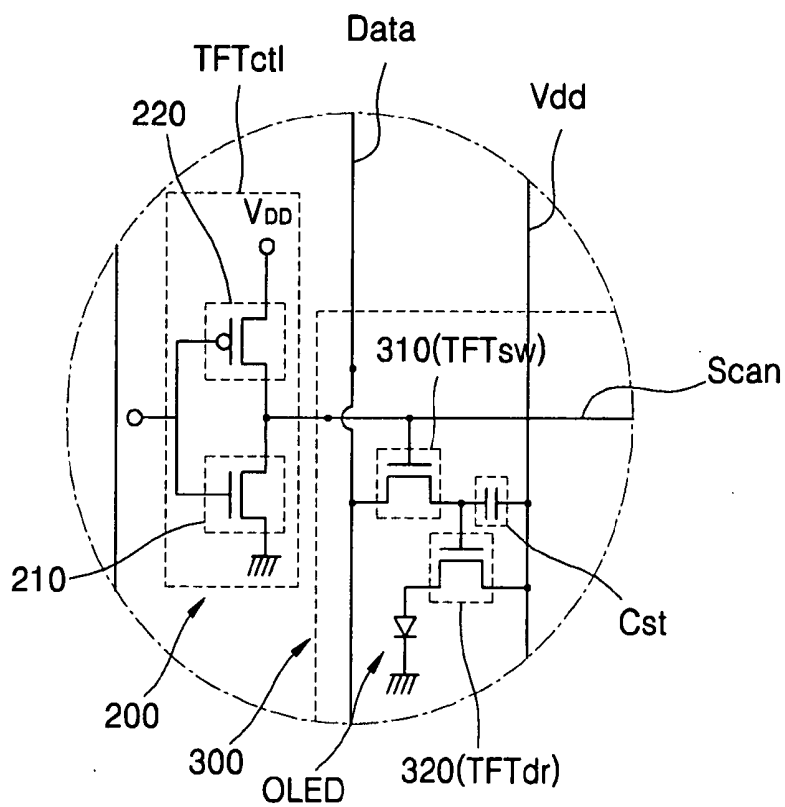

FIG. 4

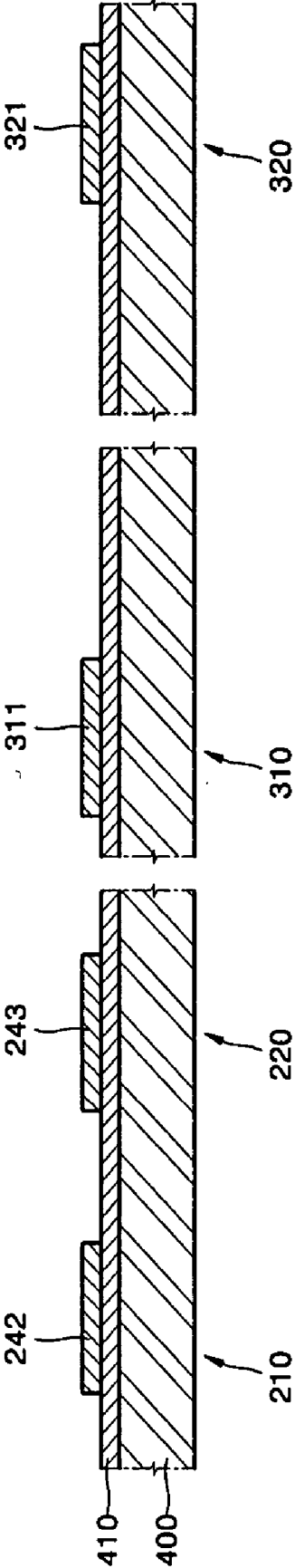

FIG. 5

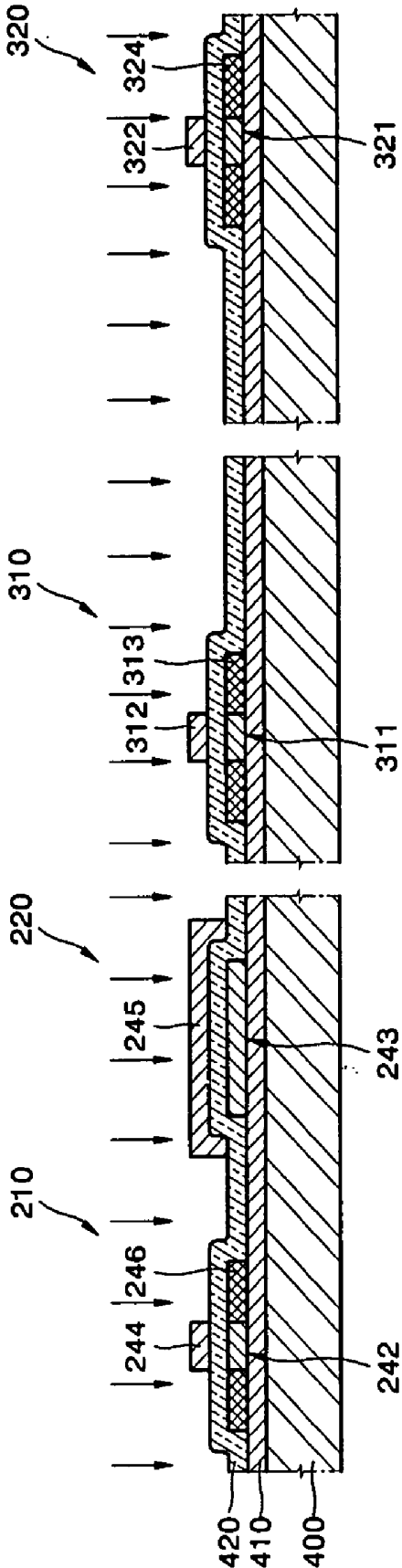

FIG. 6

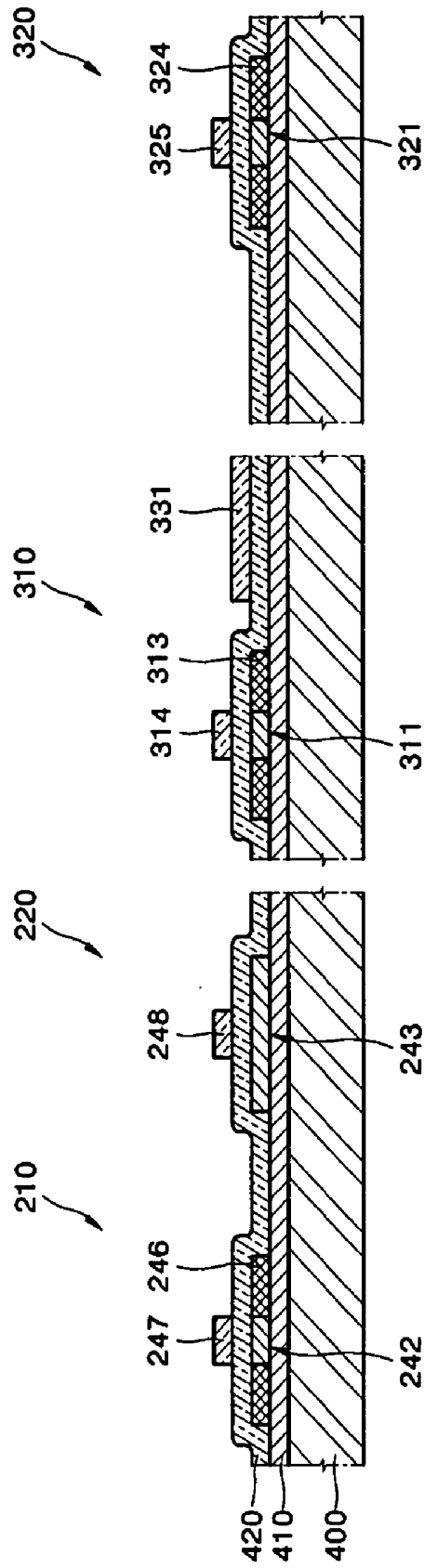

FIG. 7

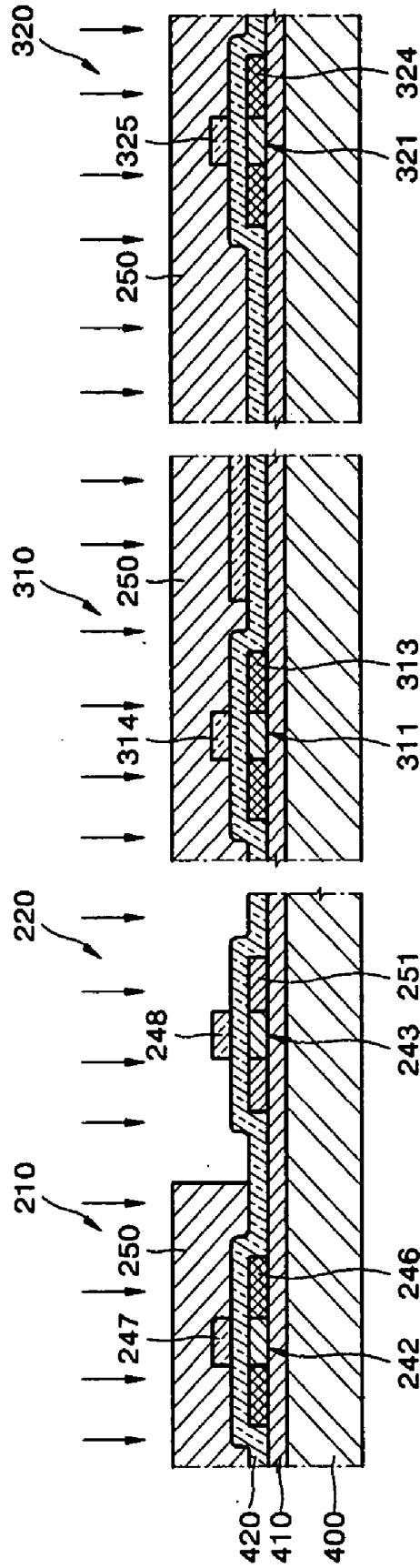

FIG. 8

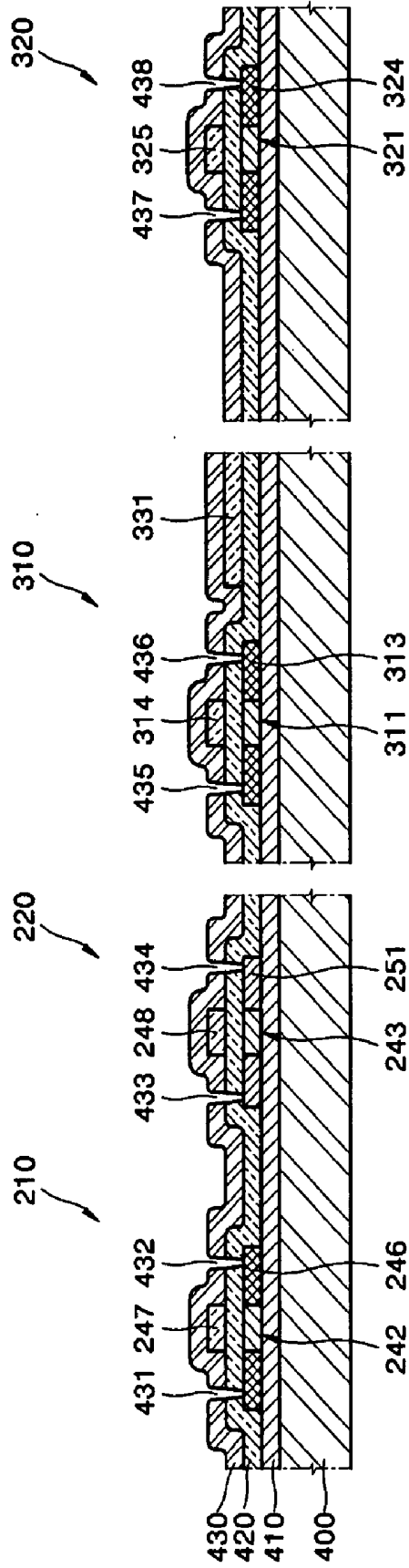

FIG. 9

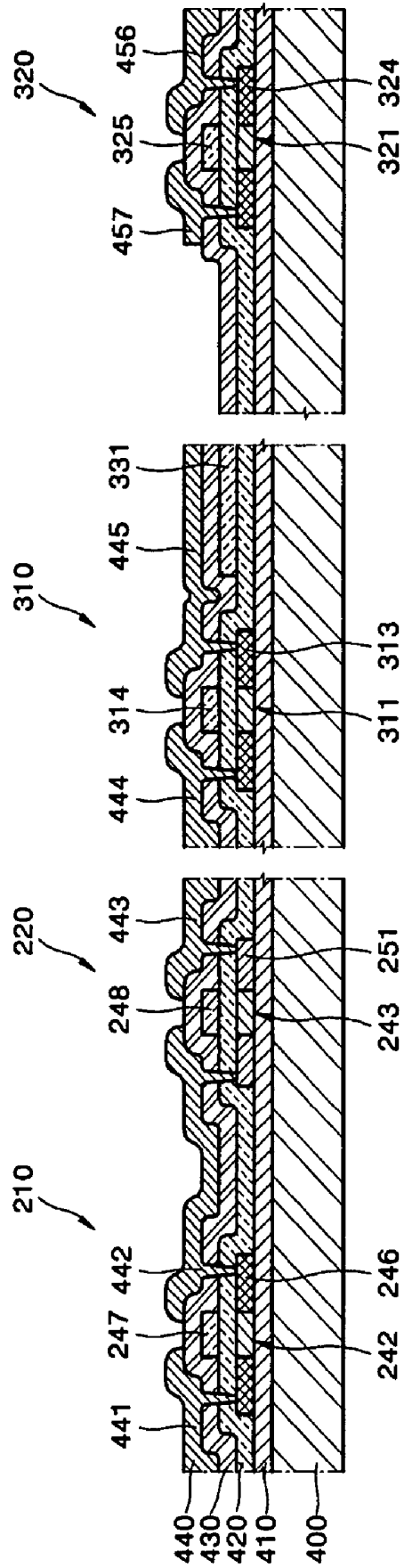

FIG. 10

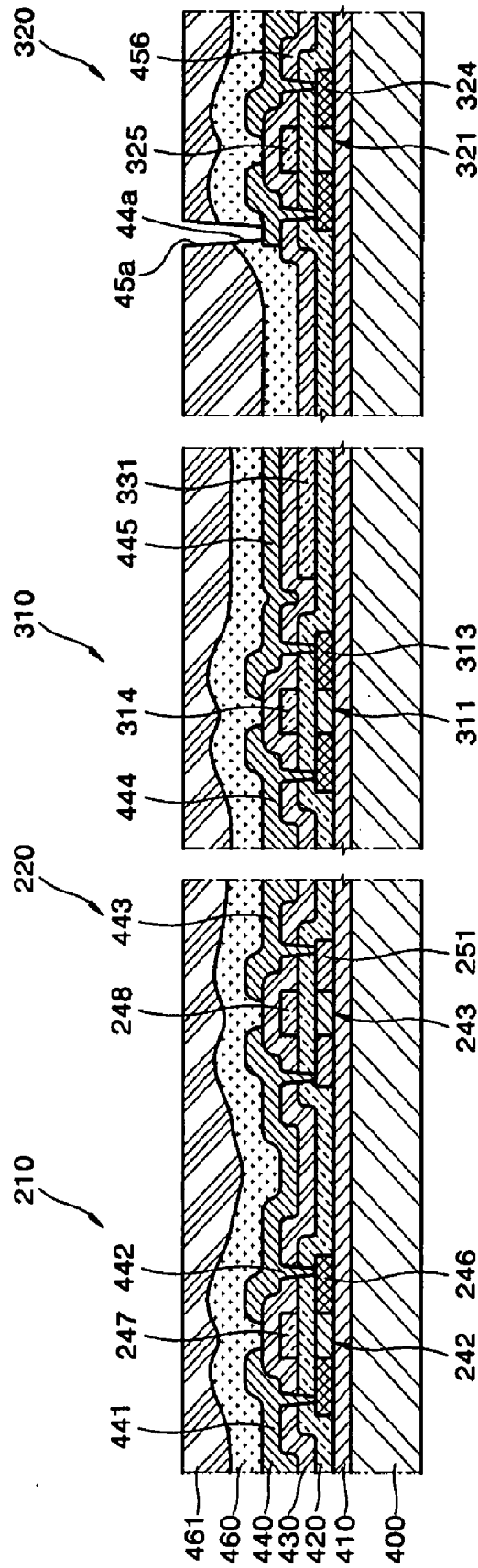

FIG. 11

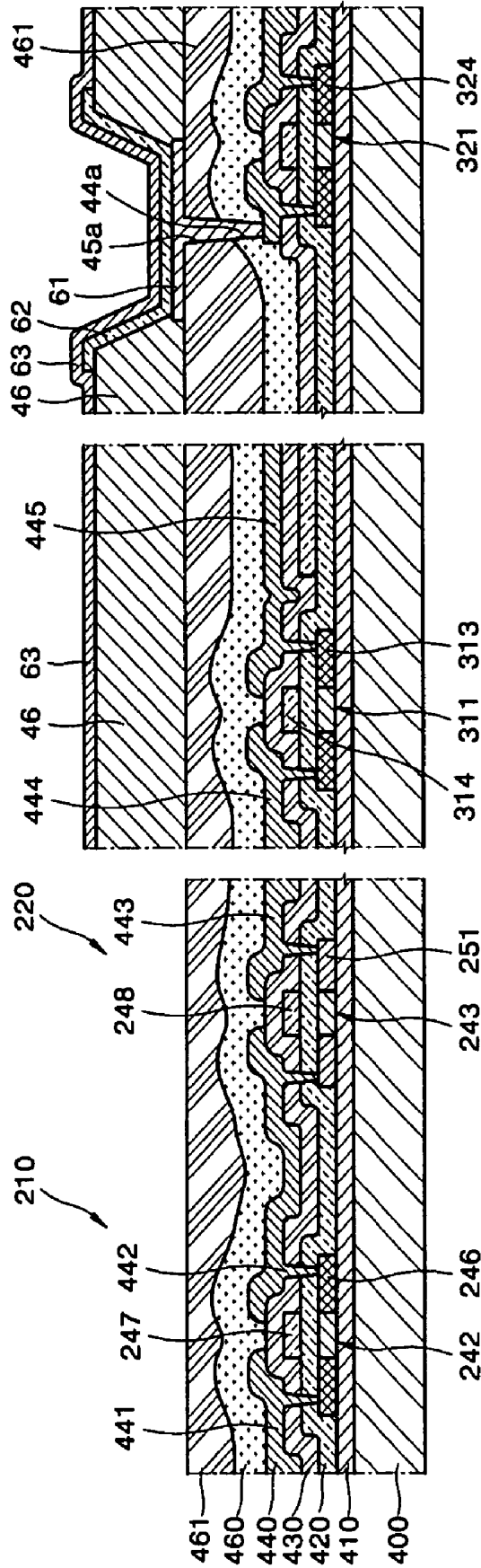

FIG. 12

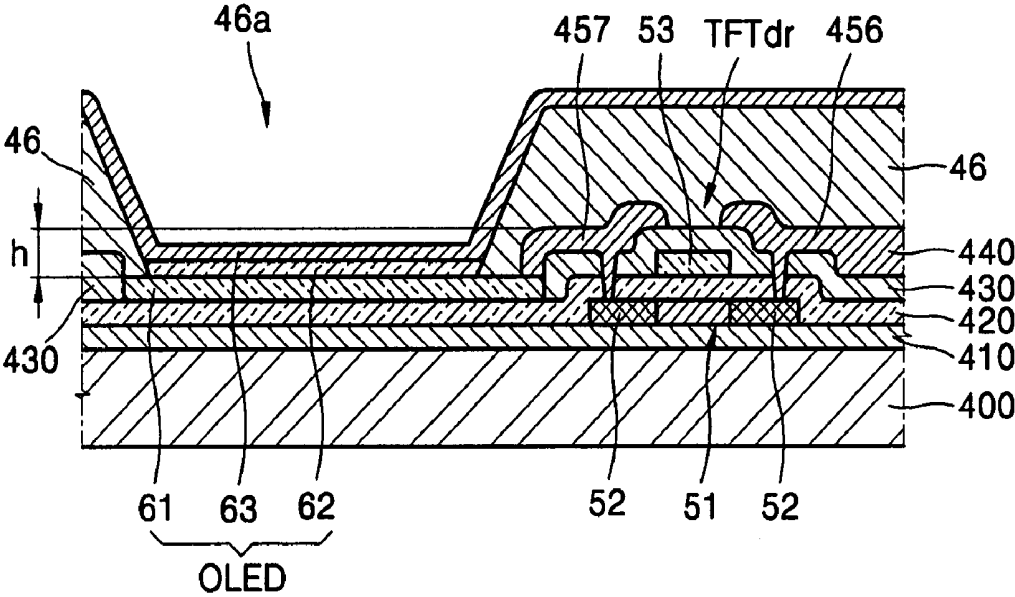

FIG. 13

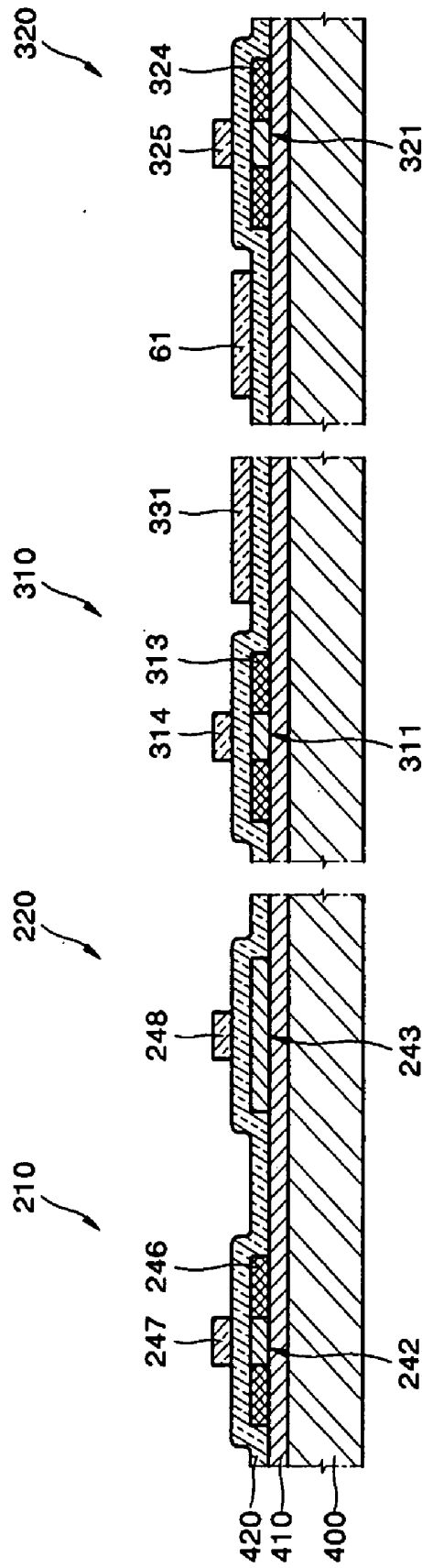

FIG. 14

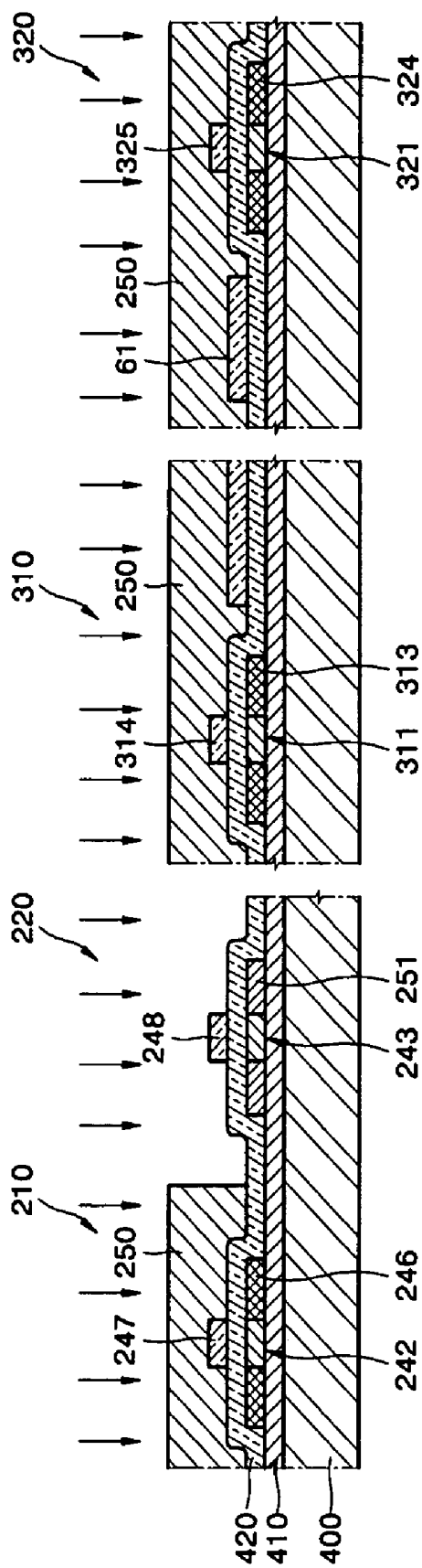

FIG. 15

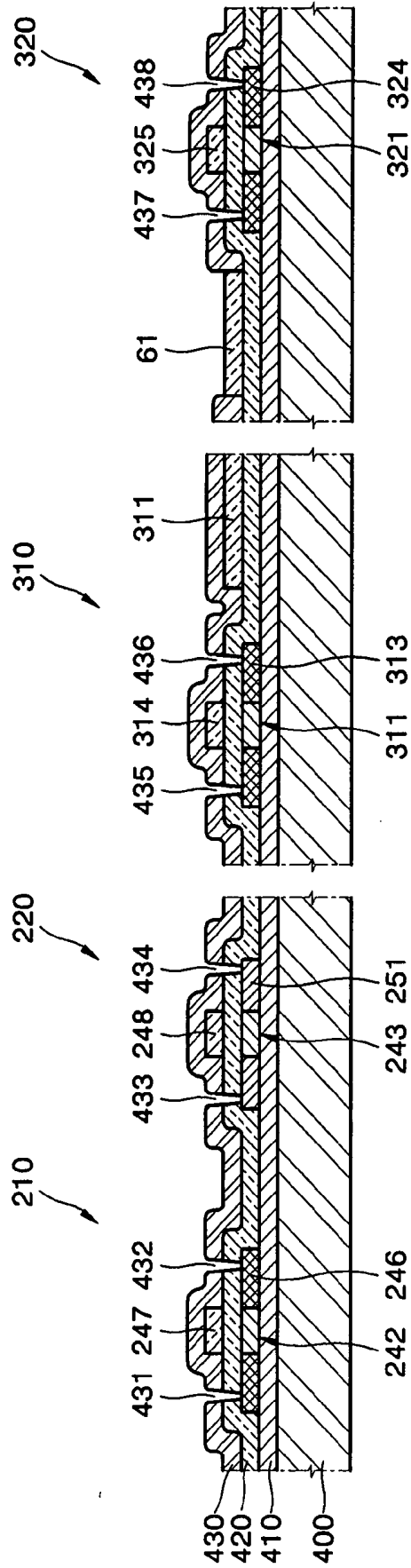

FIG. 16

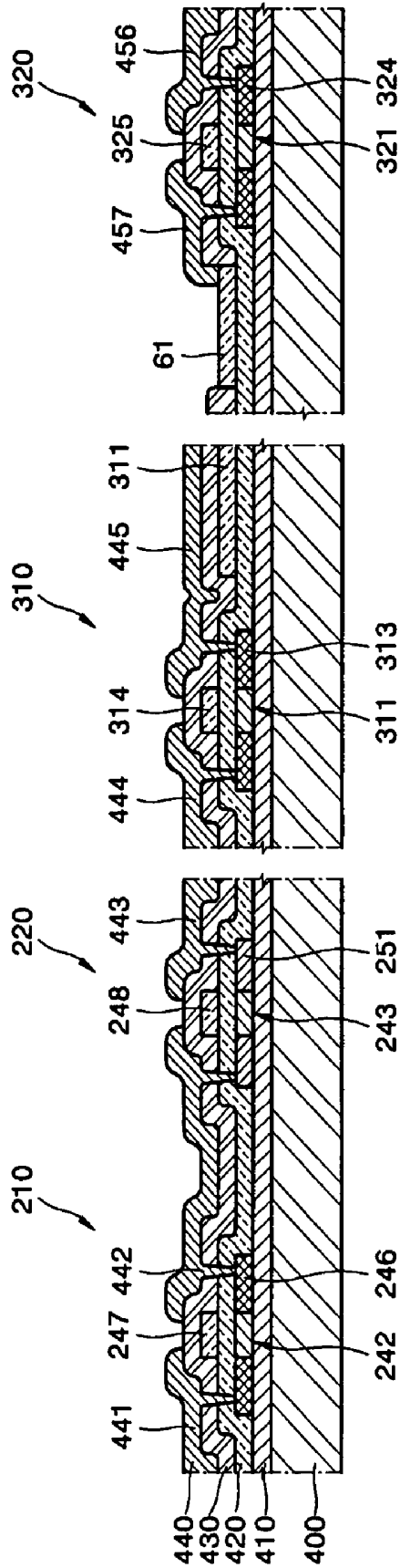
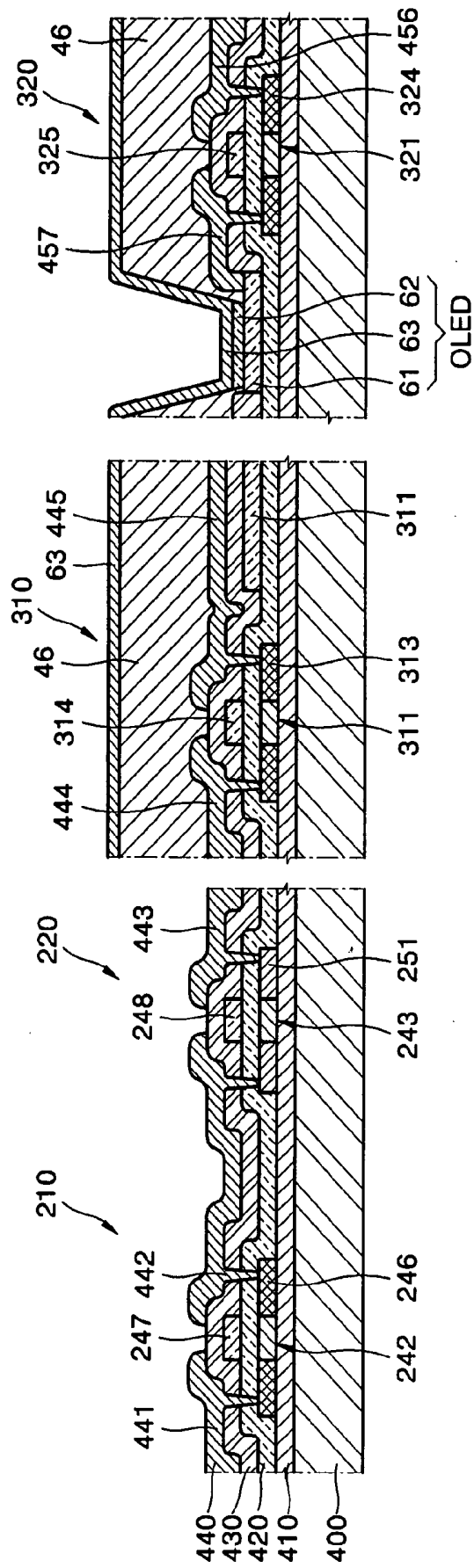

FIG. 17



**ORGANIC ELECTROLUMINESCENCE DISPLAY
DEVICE AND METHOD OF FABRICATING THE
SAME**

CROSS REFERENCE TO RELATED
APPLICATION

[0001] This application claims priority to and the benefit of Korean Patent Application No. 10-2004-0013005, filed on Feb. 26, 2004, which is hereby incorporated by reference for all purposes as if fully set forth herein.

BACKGROUND OF THE INVENTION

[0002] 1. Field of the Invention

[0003] The present invention relates to an organic electroluminescence display device and a method of manufacturing an organic electroluminescence display device, and more particularly, to an organic electroluminescence display device in which a gate electrode of a driving transistor and an electrode of an organic electroluminescence device are patterned simultaneously, thereby reducing the number of masks used in the manufacturing process.

[0004] 2. Discussion of the Background

[0005] Generally, electroluminescence display devices are self-emitting displays in which fluorescent organic compounds are electrically excited to emit light. These display devices may be operated at low voltages, may be formed with thin films, and have wide viewing-angles and rapid response. Therefore, they are regarded as next-generation displays to replace liquid display devices.

[0006] Electroluminescence display devices may be inorganic or organic devices according to whether a light-emitting layer comprises an inorganic or organic material.

[0007] An organic electroluminescence display device includes an organic film, which may be formed in a predetermined pattern between electrode layers on a transparent insulating substrate, such as glass.

[0008] In the organic electroluminescence display device, applying a voltage to an anode electrode causes holes to migrate from the anode to a light emitting layer via a hole transport layer, and applying a voltage to a cathode electrode causes electrons to migrate from the cathode to the light emitting layer via an electron transport layer. The electrons and the holes recombine in the light emitting layer to create excitons, and when the excitons transition from an excited to a ground state, fluorescent molecules of the light emitting layer emit light, thereby forming images.

[0009] Active matrix (AM) organic electroluminescence display devices include at least two thin film transistors (TFTs) per pixel. One TFT may be used as a switching device that controls the pixel's operation, and the other may be used as a driving device that drives the pixel.

[0010] A TFT includes a semiconductor layer having drain and source regions, which may be doped with highly-concentrated impurities, and having a channel area formed between the drain and source regions, a gate insulator formed on the semiconductor layer, a gate electrode formed on the gate insulator above the channel area, and drain and source electrodes connected to the drain and source regions,

respectively, via a contact hole. An interlayer insulator is interposed between the drain and source electrodes and the gate electrode.

[0011] FIG. 1 shows an effective display area 110 and a non-effective display area 120 of an organic electroluminescence display device 100. FIG. 2 is a circuit diagram of an image displaying transistor unit 300, which is formed in the effective display area 110, and a driving signal controlling transistor unit 200, which is formed in the non-effective display area 120.

[0012] The driving signal controlling transistor unit 200 may include a combination of various transistor logics, and it transmits a driving signal via a scan line to toggle a switching transistor TFT_{sw} 310 of the image displaying transistor unit 300.

[0013] The image displaying transistor unit 300 may include at least one switching transistor TFT_{sw} 310, at least one driving transistor TFT_{dr} 320, and a rechargeable capacitor C_{st} . The switching transistor TFT_{sw} 310 is driven by a scanning signal Scan, and it transmits a data signal Data applied to a data line. The driving transistor TFT_{dr} determines the amount of current flowing into an organic electroluminescence device OLED via a driving line Vdd according to the data signal transmitted through the switching transistor TFT_{sw} , that is, according to the voltage difference (V_{gs}) between a gate and a source. The rechargeable capacitor C_{st} stores the data signal that is transmitted through the switching transistor TFT_{sw} during one frame.

[0014] A conventional method of manufacturing such an organic electroluminescence display device requires as many as 10 masks. The use of so many masks may prolong and complicate the manufacturing process, thereby resulting in higher manufacturing costs.

SUMMARY OF THE INVENTION

[0015] The present invention provides a method for manufacturing an organic electroluminescence device that utilizes less pattern masks in order to economically and quickly fabricate the device.

[0016] The present invention also provides an organic electroluminescence device that may have improved luminous efficiency.

[0017] Additional features of the invention will be set forth in the description which follows, and in part will be apparent from the description, or may be learned by practice of the invention.

[0018] The present invention discloses an organic electroluminescence display device comprising a thin film transistor including a semiconductor layer disposed over a substrate, a gate electrode disposed above the semiconductor layer, and source and drain electrodes coupled to source and drain regions of the semiconductor layer, respectively. A first electrode layer is coupled to one of the source and drain electrodes, and it is disposed on the same layer as the gate electrode. A second electrode layer is disposed above the first electrode layer, and an organic layer, interposed between the first electrode layer and the second electrode layer, includes at least a light emitting layer.

[0019] The present invention also discloses a method for manufacturing an organic electroluminescence display

device, comprising forming a thin film transistor by forming a semiconductor layer disposed over a substrate, a gate electrode disposed above the semiconductor layer, and a source electrode coupled to a source region of the semiconductor layer and a drain electrode coupled to a drain region of the semiconductor layer. A first electrode layer is formed on the same layer as the gate electrode and coupled to either the source electrode or the drain electrode. An organic layer is formed between the first electrode layer and a second electrode layer, and the organic layer has at least a light emitting layer.

[0020] The present invention also discloses a method for manufacturing an organic electroluminescence display device including a plurality of imaging transistors disposed in an image area defined by a display substrate and controlling transistors disposed in a non-image area surrounding the image area. The method includes forming a first semiconductor layer, a second semiconductor layer, a third semiconductor layer, and a fourth semiconductor layer by patterning a semiconductor thin film formed on the display substrate using a first pattern mask; first ion-doping both ends of at least one of the first, second, third, and fourth semiconductor layers using a first ion and a second pattern mask after forming a first insulator on the first, second, third, and fourth semiconductor layers; forming on the first insulator gate electrodes corresponding to the first, second, third, and fourth semiconductor layers, and a first electrode layer in a predetermined portion where a light emitting layer is to be disposed, using a third pattern mask; second ion doping both ends of at least one of the first, second, third, and fourth semiconductor layers using a fourth pattern mask; forming in a second insulator formed on the first insulator contact holes extending to the ion-doped areas using a fifth pattern mask, and removing a portion of the second insulator disposed on the first electrode layer; forming a source electrode and a drain electrode extending through the contact holes on the second insulator using a sixth pattern mask such that one of the source electrode and the drain electrode is coupled to the first electrode layer; and patterning a pixel defining area using a seventh pattern mask after forming a planarizing layer on the source electrode and the drain electrode.

[0021] It is to be understood that both the foregoing general description and the following detailed description are exemplary and explanatory and are intended to provide further explanation of the invention as claimed.

BRIEF DESCRIPTION OF THE DRAWINGS

[0022] The accompanying drawings, which are included to provide a further understanding of the invention and are incorporated in and constitute a part of this specification, illustrate embodiments of the invention and together with the description serve to explain the principles of the invention.

[0023] FIG. 1 is a schematic diagram showing an effective display area and a non-effective display area of an organic electroluminescence display device.

[0024] FIG. 2 is a simplified circuit diagram showing an image displaying transistor unit formed in the effective display area and a driving signal controlling transistor unit formed in the non-effective display area of the organic electroluminescence display device of FIG. 1.

[0025] FIG. 3 is a sectional view of a conventional organic electroluminescence display device.

[0026] FIG. 4, FIG. 5, FIG. 6, FIG. 7, FIG. 8, FIG. 9, FIG. 10 and FIG. 11 are sectional views showing a method of manufacturing a conventional organic electroluminescence display device.

[0027] FIG. 12 is a sectional view of an organic electroluminescence display device according to an exemplary embodiment of the present invention.

[0028] FIG. 13, FIG. 14, FIG. 15, FIG. 16, FIG. 17 are sectional views showing a method of manufacturing an organic electroluminescence display device according to an exemplary embodiment of the present invention.

DETAILED DESCRIPTION OF THE ILLUSTRATED EMBODIMENTS

[0029] FIG. 3 is a sectional view showing a portion of a conventional organic electroluminescence display device including a driving transistor TFT_{dr}. Referring to FIG. 3, a buffer layer 410, a TFT, and an OLED are sequentially formed on a glass substrate 400.

[0030] The organic electroluminescence display device of FIG. 3 may be manufactured in the following manner.

[0031] First, a buffer layer 410 is formed on a substrate 400. A semiconductor layer 51 is formed in a predetermined pattern on the buffer layer 410. A gate insulator 420, which may be made of a material such as SiO₂, is formed on the semiconductor layer 51, and a gate electrode 53, which may be made of a material such as MoW or Al/Cu, is formed on a predetermined portion of an upper surface of the gate insulator 420. The gate electrode 53 may be coupled to a gate line (not shown) supplying TFT on/off signals. An inter-insulator 430 is formed on the gate electrode 53. Source and drain electrodes 440 may contact source and drain regions 52, respectively, of the semiconductor layer 51 via contact holes. A passivation layer 460 is formed on the source and drain electrodes 440, and a planarizing layer 461 is formed on the passivation layer 460. The passivation layer 460 may comprise SiO₂ or SiNx, and the planarizing layer 461 may comprise an organic material such as acrylic, polyimide, or BCB.

[0032] Via holes 44a and 45a extending to the source and drain electrodes 440 may be formed in the passivation layer 460 and the planarizing layer 461 using photolithography or punching. A first electrode layer 61, as an anode electrode, may be formed on the planarizing layer 461 and be coupled to the source or drain electrode 440. An organic pixel defining layer 46 may be formed to cover the first electrode layer 61. A predetermined aperture 46a is formed in the pixel defining layer 46, and an organic layer 62, including a light emitting layer, is formed in an area defined by the aperture 46a. A second electrode layer 63, as a cathode electrode, may be formed to cover the organic layer 62. Holes and electrons may be injected into a portion of the organic layer 62 interposed between the first electrode layer 61 and the second electrode layer 63 to emit light.

[0033] The driving signal controlling transistor unit 200, which acts as a driving integrated circuit (IC), formed in the non-effective display area 120, and the image displaying transistor unit 300 may be formed at the same time.

[0034] FIG. 4, FIG. 5, FIG. 6, FIG. 7, FIG. 8, FIG. 9, FIG. 10 and FIG. 1 show a manufacturing process in which controlling transistors TFT_{ct} 210 and 220 are formed in the non-effective display area 120 and a switching transistor TFT_{sw} 310, a driving transistor TFT_{dr} 320, and a rechargeable capacitor C_{st} are formed in the effective display area 110.

[0035] Referring to FIG. 4, a buffer layer 410 is formed on the entire upper surface of a display substrate 400, and a poly-silicon thin film layer is formed to a predetermined thickness on the buffer layer 410.

[0036] A photoresist thin film is formed on the poly-silicon thin film layer. Using a first pattern mask, a plurality of semiconductor layers 242, 243, 311, and 321 having predetermined areas are respectively formed in regions corresponding to a plurality of subsequently formed TFTs 210, 220, 310, and 320.

[0037] The TFTs 210 and 220, which are formed in the non-effective display area 120, may include a N type semiconductor layer 242 and a P type semiconductor layer 243, respectively. The thin film transistors 310 and 320, which are formed in the effective display area 110, include a first semiconductor layer 311 and a second semiconductor layer 321, respectively. Referring to FIG. 5, after forming the semiconductor layers 311 and 321 using the first pattern mask, a first insulator 420 is formed to a predetermined thickness on the buffer layer 410 and the semiconductor layers 242, 243, 311, and 321.

[0038] A plurality of ion barrier layers 244, 245, 312, and 322, which are patterned using a second pattern mask, are formed on an upper surface of the first insulator 420. Ion injecting equipment is used to ion dope portions of the semiconductor layers 242, 243, 311, and 321 that are not shielded by the ion barrier layers 244, 245, 312, and 322 with an N dopant, thereby forming ion doping regions 246, 313, and 324.

[0039] Referring to FIG. 6, the ion barrier layers 244, 245, 312, 322 are removed after completing the ion doping. A conducting gate material is then deposited to a predetermined thickness on the first insulator 420 to form a gate thin film and patterned using a third pattern mask, thereby forming gate electrodes 247, 248, 314, and 325. Additionally, a portion of the gate thin film is used to form a first electrode 331 of the rechargeable capacitor C_{st} .

[0040] Referring to FIG. 7, using a fourth pattern mask, a photoresist pattern 250 is formed on the gate electrodes 247, 314, and 325, the first electrode 331 and the first insulator 420. It is not formed on the region adjacent to the gate electrode 248. The semiconductor layer 243 is then ion-doped with a P type dopant, thereby forming an ion doping region 251 in the P type semiconductor layer 243.

[0041] Referring to FIG. 8, after removing the photoresist pattern 250, a second insulator 430 is formed to a predetermined thickness on the first insulator 420, the first electrode 331, and the gate electrodes 247, 248, 314, and 325. The second insulator 430 is patterned using a fifth pattern mask to form contact holes 431, 432, 433, 434, 435, 436, 437, and 438 in portions of the first and second insulators 420 and 430 corresponding to upper surfaces of the ion doping area 246 of the N type semiconductor layer 242, the ion doping area 251 of the P type semiconductor layer 243, the ion doping

area 313 of the first semiconductor layer 311, and the ion doping area 324 of the second semiconductor layer 321, respectively.

[0042] Referring to FIG. 9, a source/drain metal layer 440 is formed to a predetermined thickness on the second insulator 430, while filling the contact holes 431, 432, 433, 434, 435, 436, 437, and 438. The source/drain metal layer 440 is patterned using a sixth pattern mask.

[0043] A portion of a drain electrode 445 formed above the first electrode 331 acts as a second electrode of the rechargeable capacitor C_{st} and the second insulator 430, which is interposed between the drain electrode 445 and the first electrode 331, acts as a dielectric. As shown in FIG. 2, a portion of the second electrode of the rechargeable capacitor C_{st} is coupled to a gate electrode of the second transistor 320, and a source electrode of the second transistor 320 is coupled to a driving line Vdd.

[0044] Referring to FIG. 10, a passivation layer 460 is formed on the source/drain metal layer 440 and the second insulator 430 and then patterned using a seventh pattern mask to form a first via hole 44a. A planarizing layer 461 is formed on the passivation layer 460 and patterned using an eighth pattern mask to form a second via hole 45a, which is connected to the first via hole 44a.

[0045] Referring to FIG. 11, an anode layer 61 is formed on the planarizing layer 461 using a ninth pattern mask such that the first electrode layer 61 is coupled to the source or drain electrode 440 via the first via hole 44a and the second via hole 45a. A pixel defining layer (PDL) 46, which may be made of materials such as acryl, BDB, or poly amid, is then formed on the first electrode layer 61 using a tenth mask. After forming the PDL 46, an organic layer 62 and a cathode layer 63 are dry-coated to complete the organic electroluminescence display device.

[0046] Hereinafter, an exemplary embodiment of the present invention will be described with reference to accompanying drawings.

[0047] FIG. 12 is a sectional view of an organic electroluminescence display device according to an exemplary embodiment of the present invention. In particular, FIG. 12 shows a portion of the organic electroluminescence display device including a driving transistor TFT_{dr} and a pixel defining area connected thereto.

[0048] Referring to FIG. 12, a buffer layer 410 is formed on a display substrate 400, and a semiconductor layer 51, a gate electrode 53, and source and drain electrodes 456 and 457 are disposed on an upper surface of the buffer layer 410.

[0049] A first insulator 420 is interposed between the semiconductor layer 51 and the gate electrode 53. A second insulator 430 is interposed between the gate electrode 53, and the source and drain electrodes 456 and 457. The source and drain electrodes 456 and 457 are coupled to source and drain regions 52, respectively, of the semiconductor layer 51 through contact holes.

[0050] A first electrode layer 61 of an organic electroluminescence device OLED may be formed as an anode layer on the first insulator 420. The first electrode layer 61 may contact either the source electrode or drain electrode 456 and 457. Therefore, unlike a conventional electroluminescence display device, the electroluminescence display device

according to an exemplary embodiment of the present invention does not have a via hole coupling the OLED and the driving transistor TFT_{dr} . Since the first electrode layer **61** and the gate electrode **53** may comprise the same material, they may be formed simultaneously, thereby shortening the manufacturing process. As noted above, either the source or drain electrode of the driving TFT may be coupled to the OLED. In the embodiment shown in **FIG. 12**, the drain electrode **457** is coupled to the OLED.

[0051] An organic layer **62** and a second electrode layer **63**, which acts as a cathode when the first electrode layer **61** acts as an anode, may be sequentially deposited on the first electrode layer **61** to complete the OLED.

[0052] A second insulator **430**, which is interposed between the gate electrode **53** and the source and drain electrodes **456** and **457**, may be divided into two regions separated by the first electrode layer **61**. Therefore, the source and drain electrodes **456** and **457**, which are formed on the second insulator **430**, may be disposed above the first electrode layer **61**. If a portion of the organic layer **62** does not extend above a height h of the source and drain electrodes **456** and **457**, light emitted laterally from the organic layer **62** may reflect from a side of the source or drain electrode **456** and **457** or from a side portion of signal lines coupled to the source or drain electrode **456** and **457**, which enhances luminous efficiency. For example, the organic layer **62** may be disposed adjacent to the source or drain electrode **456** or **457**, a data line *Data* of **FIG. 2**, or a driving line *Vdd* of **FIG. 2**, all of which may be disposed on the second insulator **430**.

[0053] Therefore, the adjacent data line *Data* and the adjacent driving line *Vdd* or the source or drain electrode **456** or **457** may reflect light emitted from the organic layer **62**, which may improve the organic electroluminescence display device's brightness.

[0054] The first electrode layer **61** and/or the gate electrode **53** may be a metal-containing reflecting electrode that reflects light emitted toward the substrate **400** to the organic layer **62**. The first electrode layer **61** and/or the gate electrode **53** may comprise at least one of Mo, MoW, Cr, Ni, Al, an Al alloy, Ag, ITO, and IZO, which have high work functions. Also, the first electrode layer **61** and/or the gate electrode **53** may comprise two or three layers including one layer comprising at least one low resistance metal, such as Mo, MoW, Cr, Ni, Al, an Al alloy, or Ag, and another layer comprising at least one of ITO and IZO.

[0055] The organic layer **62**, which includes a light emitting layer, is interposed between the first electrode layer **61** and the second electrode layer **63**. The organic layer **62** may be a low weight molecular organic layer or a polymer organic layer. If it is a low weight molecular organic layer, it may include a hole injection layer (HIL), a hole transport layer (HTL), an organic emission layer (EML), an electron transport layer (ETL), an electron injection layer (EIL), or a composite structure of these. In this case, the organic layer **62** may comprise copper phthalocyanine (CuPc), N,N'-di(naphthalene-1-yl)-N,N'-diphenyl-benzidine (NPB), tris-8-hydroxyquinoline aluminum (Alq_3), or other like substances. The low weight molecular organic layer may be formed using a dry deposition method.

[0056] The polymer organic layer may include an HTL and an EML. The HTL may comprise polyethylenethiox-

ythiophene (PEDOT), and the EML may comprise poly-phenylenevinylenes (PPV), polyfluorenes, or other like substances. The polymer organic layer may be formed using screen printing, inkjet printing, or other like methods.

[0057] The organic layer is not limited to the above description, as it may have many forms.

[0058] The organic electroluminescence display device according to an exemplary embodiment of the present invention may be manufactured using less masks than conventionally, and it may have enhanced luminous efficiency. A method of manufacturing an organic electroluminescence display device according to an exemplary embodiment of the present invention will now be described.

[0059] An effective display area **110** and a non-effective display area **120** may be divided as shown in **FIG. 1**, and an image displaying transistor unit **300** and a driving signal controlling transistor unit **200** may have the same connections as in the circuit diagram of **FIG. 2**.

[0060] The image displaying transistor unit **300** may include at least one switching transistor TFT_{sw} , at least one of driving transistor TFT_{dr} , and a rechargeable capacitor C_{st} per pixel. Each pixel may be coupled to a scan line *Scan*, a data line *Data*, and a driving line *Vdd*. The image displaying transistor unit **300** may have additional TFTs and capacitors.

[0061] In **FIG. 13**, **FIG. 14**, **FIG. 15**, **FIG. 16** and **FIG. 17**, controlling transistors **210** and **220** may be formed in the non-effective display area **120** when a switching transistor TFT_{sw} , **310**, a driving transistor TFT_{dr} , **320** and a rechargeable capacitor C_{st} are formed in the effective display area **110**.

[0062] Referring to **FIG. 13**, a buffer layer **410** may be formed on the entire surface of a display substrate **400** having a predetermined area.

[0063] If the display substrate **400** has alkali, the buffer layer **410** prevents diffusion of impure ions from the display substrate **400** into a TFT formed above it. On the other hand, if the display substrate **400** is alkali-free, the buffer layer **410** may be omitted. The buffer layer **410**, which may comprise SiO_2 or other like substances, may be deposited at about 3000 Å thick using a variety of methods, such as Plasma Enhanced Chemical Vapor Deposition (PECVD), Atmospheric Pressure Chemical Vapor Deposition (APCVD), Low Pressure Chemical Vapor Deposition (LPCVD), and Electron Cyclotron Resonance (ECR).

[0064] A poly silicon thin film layer, which may be about 500 Å thick, may be formed on the buffer layer **410** or the display substrate **400** using a variety of methods. For example, amorphous silicon formed on the display substrate **400** or the buffer layer **410** may be transformed into poly silicon by a razor crystal process. Alternatively, poly silicon may be directly formed on the display substrate **400** or the buffer layer **410**.

[0065] A photoresist thin film is formed on the poly silicon thin film layer. Then, using a first pattern mask, semiconductor layers **242**, **243**, **311**, and **321** having predetermined areas may be formed in regions corresponding to the TFTs **210**, **220**, **310** and **320**.

[0066] The two TFTs to be formed in the non-effective display area **120** may be an N type transistor **210** and a P

type transistor **220**. The two TFTs to be formed in the effective display area **110** may be a switching transistor TFT_{sw} **310** and a driving transistor TFT_{dr} **320**, respectively. The N type transistor **210** includes an N type semiconductor layer **242**, the P type transistor **220** includes a P type semiconductor layer **243**, the switching transistor **310** TFT_{sw} includes a first semiconductor layer **311**, and the driving transistor **320** TFT_{dr} includes a second semiconductor layer **321**. After forming the semiconductor layers **242**, **243**, **311**, and **321**, a first insulator **420** may be formed to a predetermined thickness on the buffer layer **410** and the semiconductor layers **242**, **243**, **311**, and **321** using a process shown in **FIG. 5**.

[0067] The first insulator **420**, which is a gate insulator, insulates the semiconductor layers **242**, **243**, **311**, and **321** from the gate electrodes **247**, **248**, **314**, and **325**, which are formed on an upper surface of the first insulator **420**.

[0068] Similar to the process shown in **FIG. 5**, ion barrier layers **244**, **245**, **312**, and **322**, which are patterned using a second pattern mask, may be formed on the upper surface of the first insulator **420**. Then, high density ion doping may be performed using ion injecting equipment to ion dope, with an N dopant, portions of semiconductor layers **242**, **243**, **311**, and **321** that are not shielded by the ion barrier layers **244**, **245**, **312**, and **322**, thereby forming ion doping areas **246**, **313**, and **324**.

[0069] After removing the ion barrier layers **244**, **245**, **312**, and **322**, a conducting metal material may be deposited to a predetermined thickness on the first insulator **420** to form a gate thin film and a first electrode layer. The gate thin film and the first electrode layer may then be patterned using a third pattern mask, thereby forming gate electrodes **247**, **248**, **314**, and **325**, a first electrode **331** of the rechargeable capacitor C_{st} , and a first electrode layer **61** of the OLED.

[0070] If desired, the first electrode **331** of the rechargeable capacitor C_{st} may be formed simultaneously with the gate electrodes **247**, **248**, **314**, and **325**, and the first electrode layer **61**.

[0071] The gate electrodes **247**, **248**, **314**, and **325** and the first electrode layer **61** may comprise a metallic material having a high work function. If the gate electrodes **247**, **248**, **314**, and **325** and the first electrode layer **61** are formed from a single film, the single film may comprise at least one of Mo, MoW, Cr, Ni, Al, Al alloy, Ag, ITO, and IZO. The gate electrodes **247**, **248**, **314**, and **325** and the first electrode layer **61** may also be formed as two or three layers, wherein one layer comprises at least one low resistance metal, such as Mo, MoW, Cr, Ni, Al, Al alloy, or Ag, and another layer comprises at least one high work function metal, such as ITO or IZO.

[0072] Referring to **FIG. 14**, after patterning gate electrodes **247**, **248**, **314**, **325** and the first electrode layer **61**, the P type semiconductor layer **243** is ion doped with a P type dopant using a photoresist pattern **250**, which is formed using a fourth pattern mask. As a result, the P type semiconductor layer **243** is ion-doped to form an ion doped area **251**.

[0073] Referring to **FIG. 15**, the photoresist pattern **250** is removed, and a second insulator **430** is formed to a predetermined thickness on the first insulator **420**, the gate electrodes **247**, **248**, **314**, and **325**, the first electrode layer **61**,

and the first electrode **331**. The second insulator **430** is patterned using a fifth pattern mask to form contact holes **431**, **432**, **433**, **434**, **435**, **436**, **437**, and **438** that extend to the ion doping area **246** of the N type semiconductor layer **242**, the ion doping area **251** of the P type semiconductor layer, and ion doping areas **313** and **324** of the first and second semiconductor layers **311** and **321**. The fifth pattern mask is formed so that the second insulator **430** may be removed from above the first electrode layer **61** in order to form a light emitting area.

[0074] Referring to **FIG. 16**, a conducting source/drain metal may be deposited to a predetermined thickness on the second insulator **430** and in the contact holes **431**, **432**, **433**, **434**, **435**, **436**, **437**, and **438** to form a source/drain metal layer **440**. The source/drain metal layer **440** is patterned using a sixth pattern mask to form a source electrode **444** and a drain electrode **445** of the switching transistor TFT_{sw} **310**, and a source electrode **456** and a drain electrode **457** of the driving transistor TFT_{dr} **320**. The sixth pattern mask is formed so that a portion of the source/drain metal layer **440** may be removed from the first electrode layer **61**, thereby permitting the first electrode layer **61** to contact either the source electrode **456** or the drain electrode **457**. **FIG. 16** shows an embodiment where the first electrode layer **61** contacts the drain electrode **457**.

[0075] A portion of the drain electrode **445** disposed above the first electrode **311** of the rechargeable capacitor C_{st} **330** may act as a second electrode of the rechargeable capacitor C_{st} , and a portion of the second insulator **430** interposed between the drain electrode **445** and the first electrode **311** may act as a dielectric. Depending on a circuit design, a portion of the second electrode of the rechargeable capacitor C_{st} may be coupled to a gate electrode **325** in the driving TFT_{dr} **320**, and the source electrode **456** of the driving TFT_{dr} **320** may be coupled to a driving line Vdd (**FIG. 2**).

[0076] Referring to **FIG. 17**, after forming a planarizing layer **46** on the second insulator **430**, the first electrode layer **61**, and the source/drain material layer **440**, a portion of the planarizing layer **46** is removed to expose the first electrode layer **61** using a seventh pattern mask, thereby forming an open area for the OLED. In other words, a light emitting area is patterned to expose the first electrode **61**, thereby forming a pixel defining area with the planarizing layer **46**.

[0077] An organic layer **62**, which includes a light emitting layer, is formed to cover a portion of the surface, or the entire surface, of the exposed first electrode layer **61**. A second electrode layer **63** covers the organic layer **62** to complete the OLED.

[0078] The OLED, which emits red, green, or blue light according to a current flow, includes the first electrode layer **61**, the second electrode layer **63**, and the organic layer **62** interposed therebetween. The second electrode layer **63** may cover the entire pixel.

[0079] The first electrode layer **61** may be an anode electrode, and the second electrode layer **63** may be a cathode electrode. On the other hand, the first electrode layer **61** may be a cathode electrode, and the second electrode layer **63** may be an anode electrode.

[0080] A manufacturing process of an organic electroluminescence display device according to an exemplary embodiment of the present invention utilizes fewer masks as

compared to conventional techniques. Accordingly, the manufacturing process of the present invention may be quicker and cheaper.

[0081] In an organic electroluminescence display device according to an exemplary embodiment of the present invention, a source/drain electrode or signal lines connected to the source/drain electrode may reflect light emitted in lateral directions from an organic layer to an area where images are formed. As a result, light efficiency may be improved, which leads to decreased power consumption. The reduced power consumption may prevent organic layer deterioration, thereby increasing the device's lifespan.

[0082] It will be apparent to those skilled in the art that various modifications and variation can be made in the present invention without departing from the spirit or scope of the invention. Thus, it is intended that the present invention cover the modifications and variations of this invention provided they come within the scope of the appended claims and their equivalents. For example, in the above-described embodiments, a pixel of the effective display area **110** includes two TFTs, but the present invention is not limited thereto. That is, the pixel may include a plurality of TFTs. In other words, even though only two TFTs are disposed in a pixel in the drawings, more TFTs can be disposed in the actual planar structure depending on a circuit design.

What is claimed is:

1. An organic electroluminescence display device, comprising:

a thin film transistor including:

a semiconductor layer disposed over a substrate;

a gate electrode disposed above the semiconductor layer; and

a source electrode coupled to a source region of the semiconductor layer and a drain electrode coupled to a drain region of the semiconductor layer, a first electrode layer coupled to either the source electrode or the drain electrode, and disposed on a same layer as the gate electrode;

a second electrode layer disposed above the first electrode layer; and

an organic layer interposed between the first electrode layer and the second electrode layer and including at least a light emitting layer.

2. The organic electroluminescence display device of claim 1, further comprising a first insulator interposed between the semiconductor layer and the gate electrode,

wherein the first electrode layer and the gate electrode are disposed on the first insulator.

3. The organic electroluminescence display device of claim 2, further comprising a second insulator interposed between the gate electrode and the source and drain electrodes,

wherein the first electrode layer is disposed in an open area of the second insulator.

4. The organic electroluminescence display device of claim 1, wherein the first electrode layer is a metal electrode.

5. The organic electroluminescence display device of claim 4, wherein the first electrode layer comprises at least

one selected from the group consisting of Mo, MoW, Cr, Ni, Al, an Al alloy, Ag, ITO, and IZO.

6. The organic electroluminescence display device of claim 5, wherein:

the first electrode layer comprises a first layer and a second layer;

the first layer comprises at least one selected from the group consisting of Mo, MoW, Cr, Ni, Al, an Al alloy, and Ag; and

the second layer comprises at least one selected from the group consisting of ITO and IZO.

7. The organic electroluminescence display device of claim 4, wherein the gate electrode is made of a same material as the first electrode layer.

8. The organic electroluminescence display device of claim 5, wherein the gate electrode is made of a same material as the first electrode layer.

9. The organic electroluminescence display device of claim 6, wherein the gate electrode has a same layer structure that is made of a same material as the first electrode layer.

10. The organic electroluminescence display device of claim 3, further comprising:

a pixel defining layer that covers the thin film transistor and exposes a portion of the first electrode layer,

wherein the organic layer is disposed on a portion of the exposed first electrode layer.

11. The organic electroluminescence display device of claim 10, wherein an upper surface of the organic layer is lower than an upper surface of the source electrode or the drain electrode.

12. The organic electroluminescence display device of claim 10, further comprising:

a first signal line coupled to the source electrode; and

a second signal line coupled to the drain electrode,

wherein an upper surface of the organic layer is lower than an upper surface of the first signal line or the second signal line.

13. A method for manufacturing an organic electroluminescence display device, comprising:

forming a semiconductor layer;

forming a first insulator covering the semiconductor layer;

forming on the first insulator a gate electrode and a first electrode layer simultaneously;

forming a second insulator covering the first insulator and the gate electrode, exposing the first electrode layer, and having two contact holes extending to the semiconductor layer; and

forming on the second insulator a source electrode and a drain electrode contacting the semiconductor layer through the contact holes respectively, such that one of the source electrode and the drain electrode is connected to the first electrode layer.

14. The method of claim 13, wherein the first electrode layer is a metal electrode.

15. The method of claim 14, wherein the gate electrode and the first electrode layer comprise at least one selected from the group consisting of Mo, MoW, Cr, Ni, Al, an Al alloy, Ag, ITO, and IZO.

16. The method of claim 15, wherein the gate electrode and the first electrode layer comprise a first layer and a second layer;

wherein the first layer comprises at least one selected from the group consisting of Mo, MoW, Cr, Ni, Al, an Al alloy, and Ag; and

wherein the second layer comprises at least one selected from the group consisting of ITO and IZO.

17. The method of claim 13, further comprising:

forming a pixel defining layer covering the second insulator, the source electrode, the drain electrode, and the first electrode layer; and

patterning the pixel defining layer to expose at least a portion of the first electrode layer.

18. The method of claim 17, further comprising:

forming an organic layer on the exposed portion of the first electrode layer, wherein the organic layer has at least a light emitting layer; and

forming a second electrode layer on the organic layer.

19. The method of claim 13, wherein a first signal line coupled to the source electrode and a second signal line coupled to the drain electrode are formed when the source electrode and the drain electrode are formed, and an upper surface of the organic layer is formed lower than an upper surface of the source electrode, the drain electrode, the first signal line, and the second signal line.

20. A method for manufacturing an organic electroluminescence display device comprising a plurality of imaging transistors disposed in an image area and a plurality of controlling transistors disposed in a non-image area surrounding the image area, the method comprising:

forming a first semiconductor layer, a second semiconductor layer, a third semiconductor layer, and a fourth semiconductor layer using a first pattern mask;

first ion-doping both ends of at least one of the first, second, third, and fourth semiconductor layers using a first ion and a second pattern mask after forming a first insulator on the first, second, third, and fourth semiconductor layers;

forming, on the first insulator, a gate electrode corresponding to each of the first, second, third, and fourth semiconductor layers, and a first electrode layer in an area where a light emitting layer is to be disposed, using a third pattern mask;

second ion doping both ends of at least one of the first, second, third, and fourth semiconductor layers using a fourth pattern mask;

forming a second insulator on the first insulator and the first electrode layer;

forming contact holes in the second insulator that extend to the ion-doped areas using a fifth pattern mask, and removing a portion of the second insulator disposed on the first electrode layer;

forming a source electrode and a drain electrode extending through the contact holes on the second insulator using a sixth pattern mask such that either a source electrode or a drain electrode is coupled to the first electrode layer; and

patterning a pixel defining area using a seventh pattern mask after forming a planarizing layer on the source electrode and the drain electrode.

* * * * *

专利名称(译)	有机电致发光显示装置及其制造方法		
公开(公告)号	US20050189874A1	公开(公告)日	2005-09-01
申请号	US11/062938	申请日	2005-02-23
[标]申请(专利权)人(译)	公园文熙 SEO张苏 吴尚HUN		
申请(专利权)人(译)	PARK文姬 SEO CHANG-SU 吴尚HUN		
当前申请(专利权)人(译)	PARK文姬 SEO CHANG-SU 吴尚HUN		
[标]发明人	PARK MOON HEE SEO CHANG SU OH SANG HUN		
发明人	PARK, MOON-HEE SEO, CHANG-SU OH, SANG-HUN		
IPC分类号	H05B33/00 H01J1/62 H01J63/04 H01L27/32 H01L51/52 H01L51/56 H05B33/10 H05B33/14		
CPC分类号	H01L27/3244 H01L27/3246 H01L51/56 H01L51/5206 H01L27/3248 H01L51/5218 H01L51/5271 H01L2227/323 E03D1/283 E03D1/38 E03D2201/40		
优先权	1020040013005 2004-02-26 KR		
其他公开文献	US7626330		
外部链接	Espacenet USPTO		

摘要(译)

一种有机电致发光显示装置，包括薄膜晶体管，第一电极层，第二电极层和有机层。薄膜晶体管包括半导体层，设置在半导体层上方的栅电极，以及与栅电极绝缘的源电极和漏电极。第一电极层耦合到源电极或漏电极，并且第一电极层和栅电极设置在同一层上。第二电极层设置在第一电极层上方，并且包括至少发光层的有机层插入在第一电极层和第二电极层之间。

